

## TWO SHIFT OPERATION POWER PLANTS

### TWO SHIFT OPERATION POWER PLANTS

Wind, solar power and other renewables energy generation creates a more flexible demand on gas fired power stations to balance the grid.

To operate in a reliable, quick, modulating and start/stop regime, some improvements are necessary.

To start and stop a CCGT installation takes time. This should be done as quick as possible to limit the starting costs and to supply as soon as possible to the grid. For all CCGT plants the demand for being reliable and to supply to the grid, is the single most important driving factor.

### MOST CRUCIAL

Crucial components in an installation are the drum level or feed water control valves. The range ability, the capability to avoid cavitation and the possibility to start and operate the boiler with one valve makes that the components have to be designed and chosen carefully.

### FEED WATER CONTROL VALVES

They control the supply of feed water to the drum. The physical demands on these valves are high. The valves should handle the start-up and full load cases and require therefor a very high range ability.

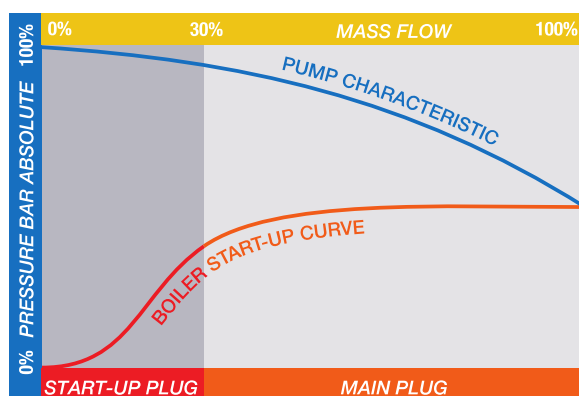

During start-up the requirements from the valve are totally different. As the valve is required to control a small mass flow with a high delta P, the required range ability can no longer be realised by one valve. Generally the solution is found in the installation of a second control valve, the start-up or the so called 30% valve. Installed parallel with the main feed water control valve. This valve can handle small mass flows at high pressure drops.

The change from the start up valve to the main valve is not an easy transition, and is done with good craftsmanship.

The feed water control set is based on a main feed water control valve and a 30% bypass start up valve. The set will also include stop valves and a lot of high pressure piping. The regular wear and tear on the 30% valve can be severe.

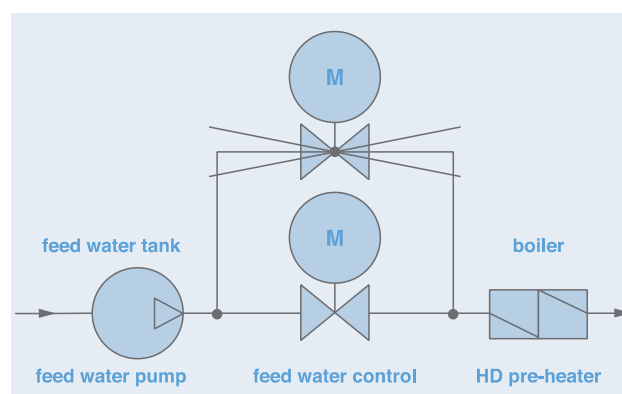

In this paper we introduce the “Combi feed water control valve”, a single control valve which is capable of controlling both the start-up conditions and the maximum loads cases.

### **HORA COMBI FEED WATER CONTROL VALVE**

The combi feed water control valve combines the different functions of the feed water set into one single valve. With only one control signal both start up and main feed control can be handled. The valve is designed to coop with all conditions. The multi stage start up plug will prevent the water from flashing. The main plug will control the normal function that is needed with a very small pressure drop.

### **THE FUNCTION**

The drawings below illustrate the trim functions.

The single stage main plug controlling the main feed water flow is determined by the perforated cage and main plug as the control is gained the moment the main plug is lifted from its seat. On startup, inside the main plug there is a secondary startup plug with 3 or 4 controlled stages and so, on initial operation of the valve, the startup plug is lifted from its small seat with the Bellville washers holding the main plug firmly closed.

When the startup plug is reaching its maximum stroke, the main plug is lifted and the main control system takes over. The startup and main control is now done by one valve and one control signal. The combi-feed water control valve is extremely easy to maintain. The complete trim is held within the body as a removable cartridge, and can be readily taken apart.

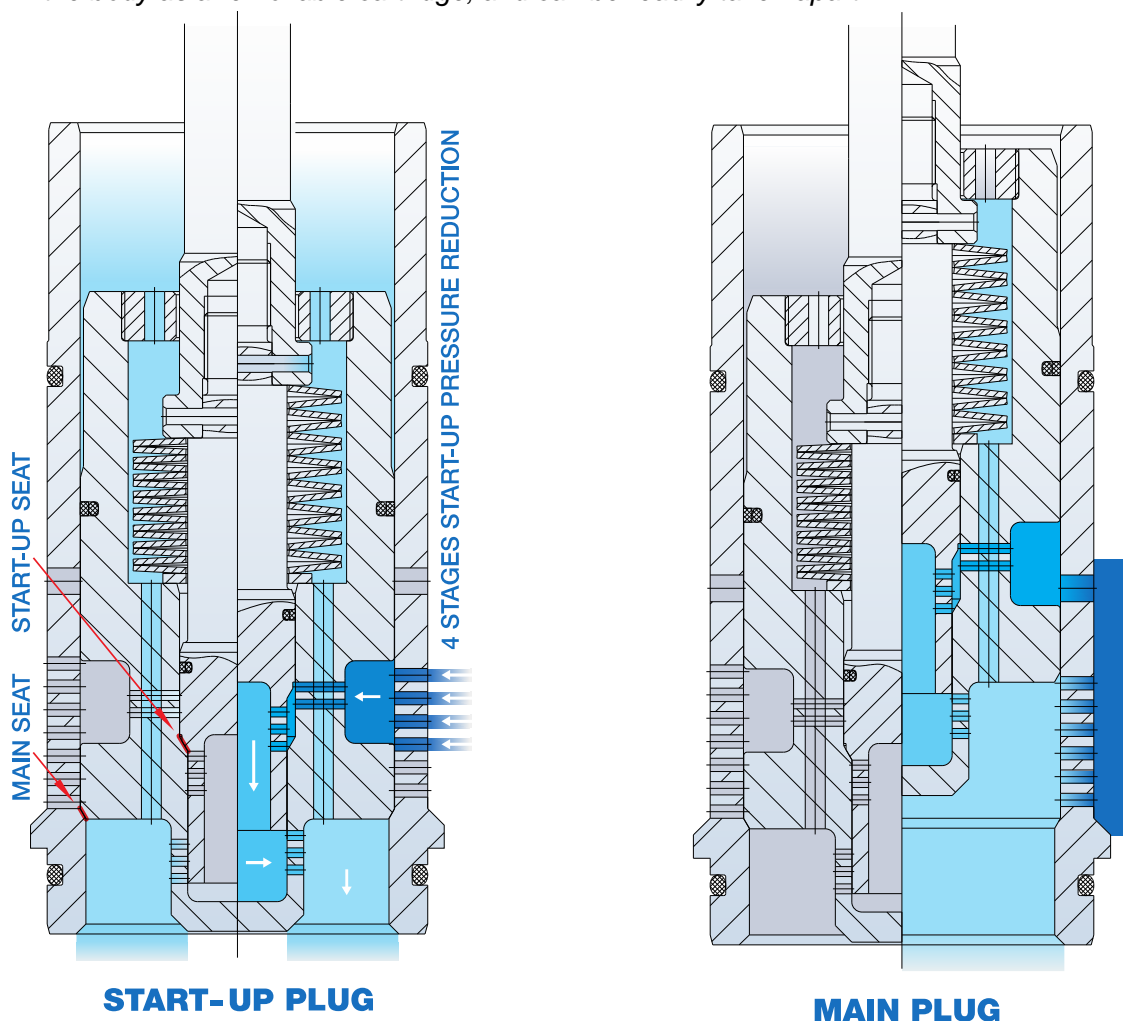

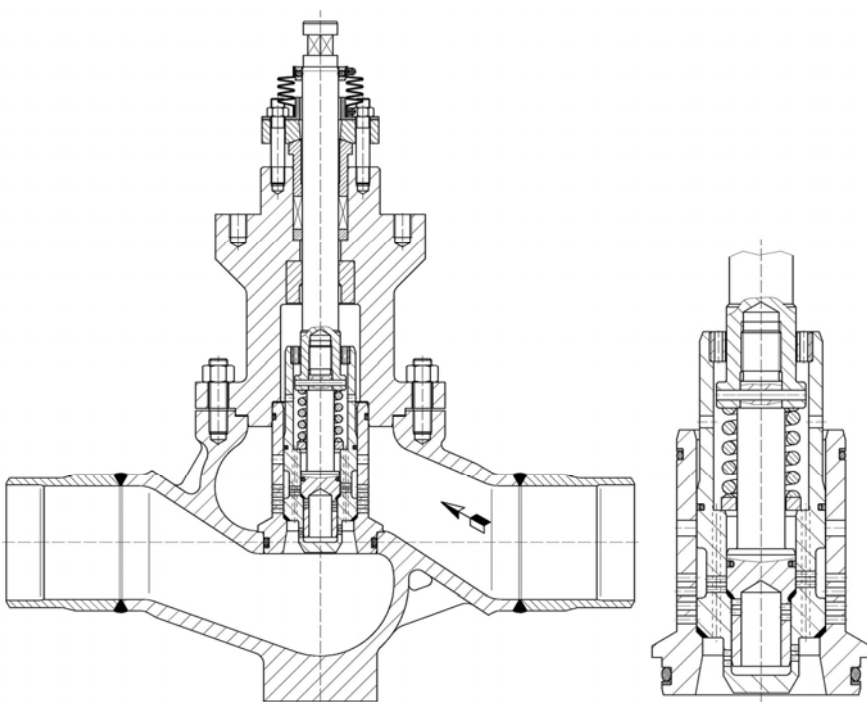

**ABOVE LEFT:**  
*Combi-feed water control valve,  
 3 staged plug and cage start up trim,  
 cast body BWE*

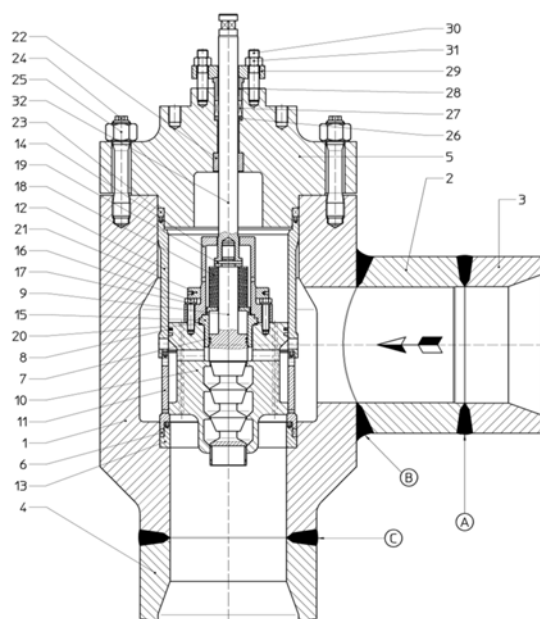

**ABOVE RIGHT:**  
*Combi-feed water control valve,  
 cascade 4 stage start up trim,  
 forged body BWE*

**Advanced Valve Solutions B.V.**

Keplerstraat 8 - 1704 SJ Heerhugowaard - The Netherlands - Tel: +31 (0)72 576 28 90  
 E-mail: [info@advancedvalvesolutions.nl](mailto:info@advancedvalvesolutions.nl) - web:www.advancedvalvesolutions.nl

**Advanced Valve Solutions UK Ltd.**

8 Solway Court – Coppicemere Drive – Crewe- Cheshire – CW1 6LD - UK – Tel: +44 1270 586 944  
 E-mail: [info@advancedvalvesolutions.co.uk](mailto:info@advancedvalvesolutions.co.uk) - web:www.advancedvalvesolutions.co.uk

**Advanced Valve Solutions USA Inc.**

184 Edie Rd Suite C, Saratoga Springs, NY 12866, USA, Tel. 516 260 2574  
 E-mail: [info@advancedvalvesolutions.com](mailto:info@advancedvalvesolutions.com) - web:www.advancedvalvesolutions.com