

TWO SHIFT OPERATION POWER PLANTS

Wind, solar power and other renewables energy generation creates a more flexible demand on gas fired power stations to balance the grid. To operate in a reliable, quick, modulating and start/stop regime, some improvements are necessary. To start and stop a CCGT installation takes time. Thermal radiances are crucial to start quickly.

This should be done as quick as possible to limit the starting costs and to supply as soon as possible to the grid.

The following paper highlights some issues found in dual shifting power stations with special regards to main on-off steam valves.

TAPERED PARRALLEL GATE VALVES

Stop valves have a crucial role in power stations. They can isolate certain parts of the installation and are operated in an on-off mode.

In the closed position the upstream pressure pushes the downstream disc on the seat and creates the seal. An adequate system, certainly in combination with an internal "rail", used for guiding the trim during opening and closing.

This valve is based on two individual separate discs, a bearing and a spindle with a forged on hammer head. This valve has a very limited number of parts in the pressure containing body.

BODY MATERIALS

Starting and stopping an installation every day will lead to thermal stress in a valve body. The thickness of the body limits the heating up. The thinner the valve body, the shorter the start-up time.

Our forged valves are designed around the pressure and temperature and do not have too much material due to a certain pressure class. Valves, based on forged materials are "athletic valves" quick in starting up and cooling down with the thinnest possible wall thickness.

Our valves are available in different materials such as **A 182 F1, F12, F22 and P91 / P92.**

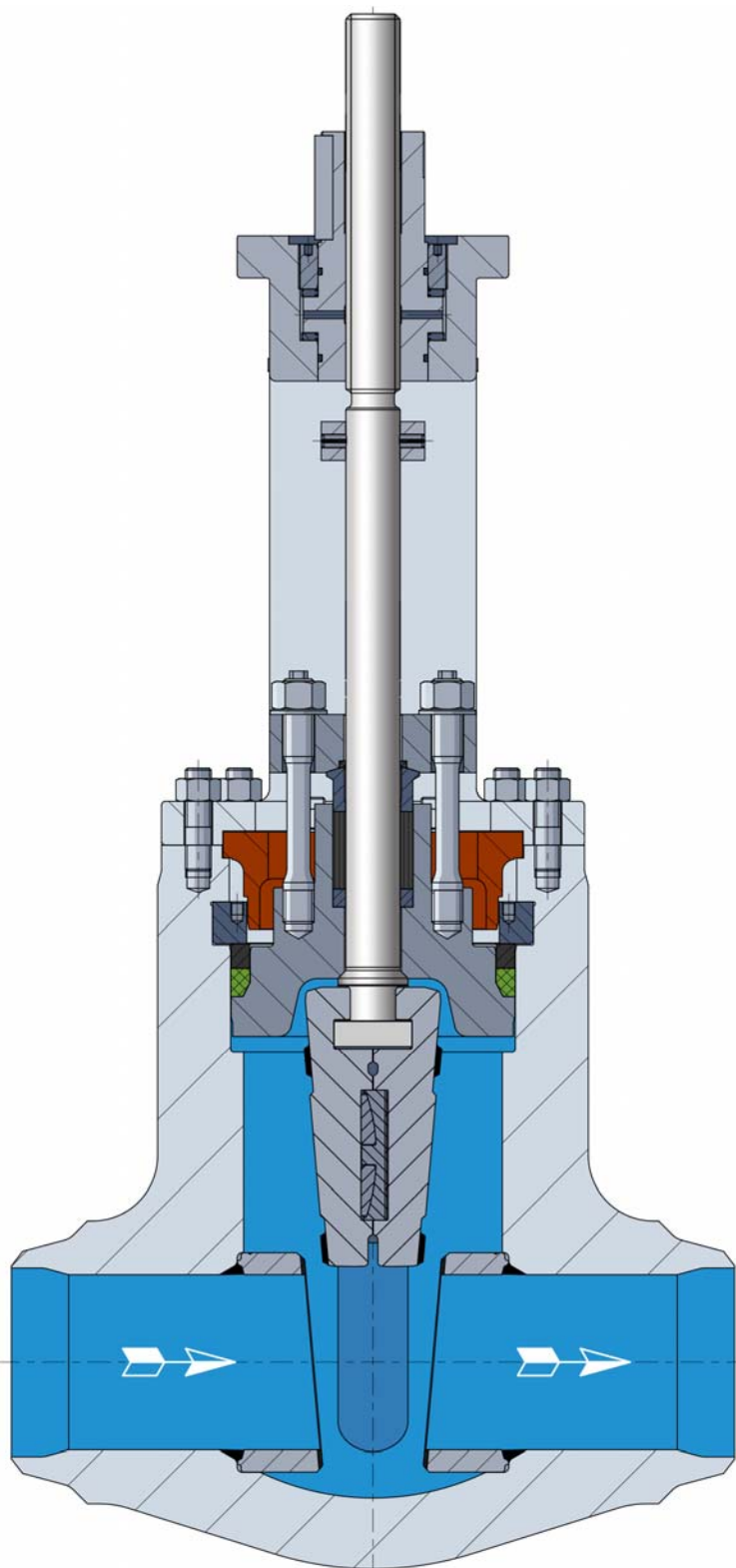

PERSTA tapered parallel slide gate valve

THERMAL CYCLING

New rules for cycling valves and the calculation of thermal stress due to heating radiant are described in the **EN12592-3** and the **EN 12516-2**. Persta is one of the first manufactures who has delivered valves to these design criteria.

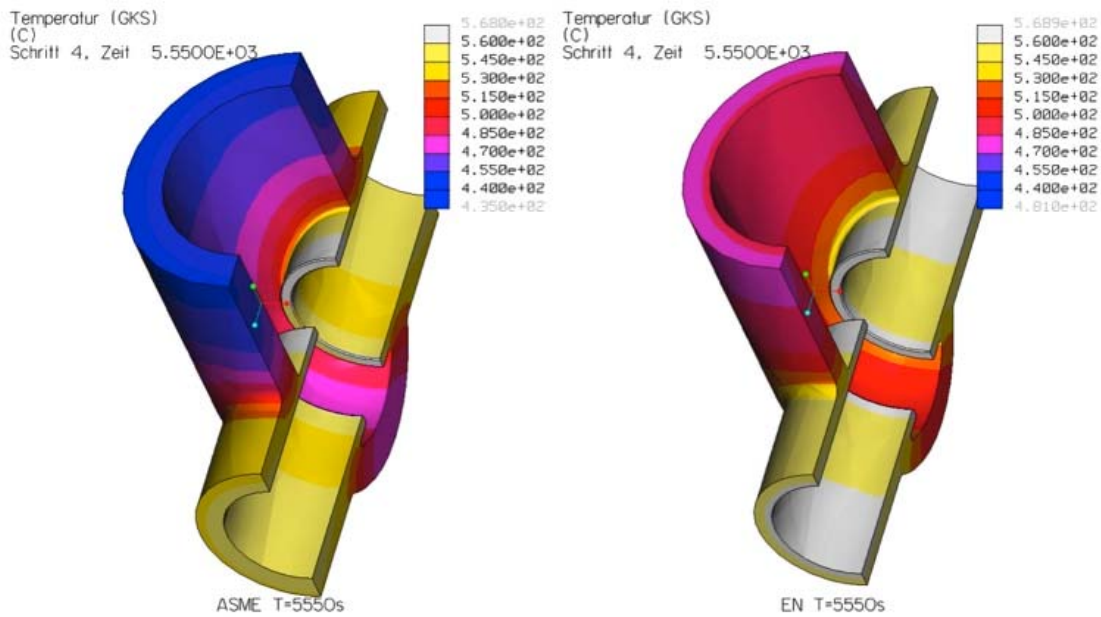

Comparison of a valve to **ASME 16.34** with a valve designed to **EN 12516-2** is available on request.

MAINTENANCE PRESSURE SEAL BONNET

After being successfully in operations for several years even a PERSTA tapered parallel slide gate valve needs inspection. In these cases the pressure seal design of Persta is different to the regular designs.

The Persta design is using a ring, as part of the yoke to fix the split pressure seal ring. This guarantees a simple and quick opening of the valve.

PERSTA valves are therefore very maintenance friendly.

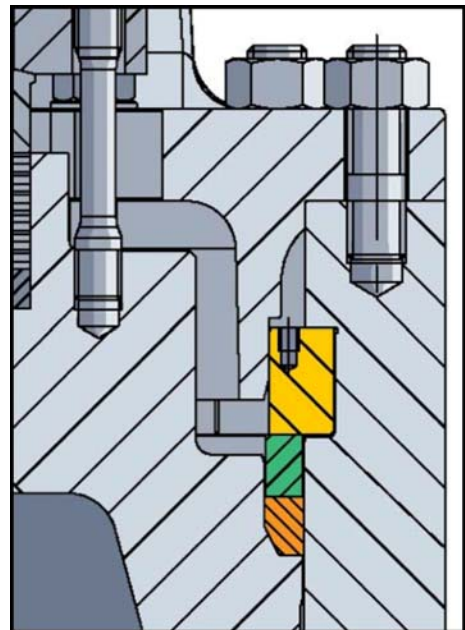

LARGE HOT REHEAT GATE VALVES



One of the installed valves in the UK in a HRSG reheat application has performed 100.000 cycles without any problems.

Large valves, such as the hot reheat shut off valves, also based on a tapered parallel slide design, often are 24, 28 or even 32" in size. The requirement to follow the heat radians during start up PERSTA developed a new type of gate valve.

Not using a casting but P91 hot forged sheets, brought together in a special procedure. The ultimate result is a valve with a wall thickness almost equal to the pipe material, light and easy to operate and no problem for the heating radians.



Valve built of forged plate, large sizes possible.

The Future ? Is already built !

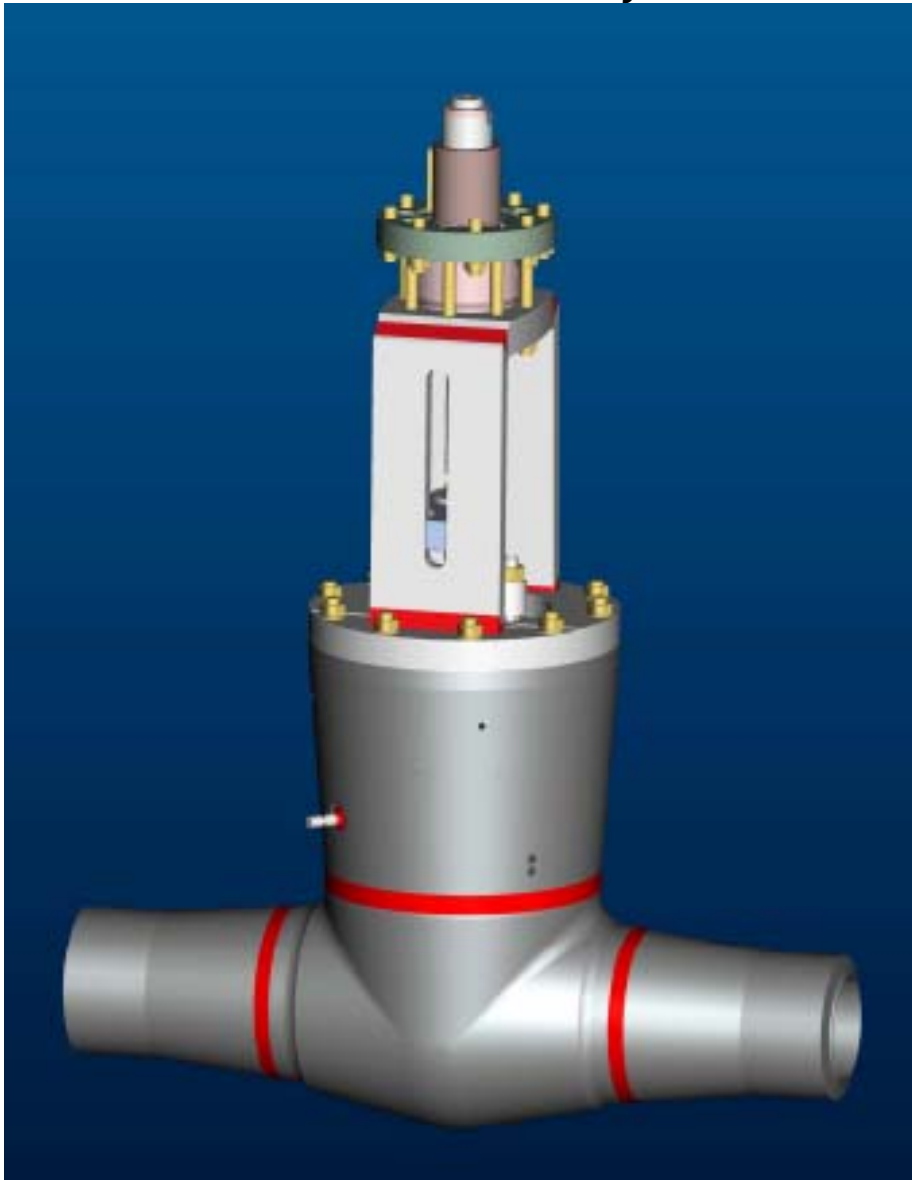

*Uniper Irsching, tapered parallel slide valve
DN300 (12') in F92 material*

Advanced Valve Solutions B.V.

Keplerstraat 8 - 1704 SJ Heerhugowaard - The Netherlands - Tel: +31 (0)72 576 28 90

E-mail: info@advancedvalvesolutions.nl - web: www.advancedvalvesolutions.nl

Advanced Valve Solutions UK Ltd.

8 Solway Court – Coppicemere Drive – Crewe- Cheshire – CW1 6LD - UK – Tel: +44 1270 586 944

E-mail: info@advancedvalvesolutions.co.uk - web: www.advancedvalvesolutions.co.uk

Advanced Valve Solutions USA Inc.

184 Edie Rd Suite C, Saratoga Springs, NY 12866, USA, Tel. 518 260 2574

E-mail: info@advancedvalvesolutions.com - web: www.advancedvalvesolutions.com