

ADVANCED VALVES SOLUTIONS INC. FOR CYCLING OPERATION

CONTINUOUS BLOW DOWN CONTROL VALVES (HORA) FOR CYCLING AND TWO SHIFT OPERATION POWER PLANTS

In modulating and start-stop operated power plants many issues are found in drain- and blow down valves.

DRAIN VALVES

Continuous blow down control valves on start stop installation face severe service conditions on an almost daily basis. These valves are affected by high velocity erosion caused by flashing, wearing out carbon steel, F12, F22 and P91 materials. Final result in all cases is leakage, internal (seat) or external (hole valve body / piping).

In cases where a boiler should be "tight overnight" this leakage is a big problem.

THE SOLUTION

The solution is found in an angle type valve with an easy exchangeable trim with a separate sealing and control edge.

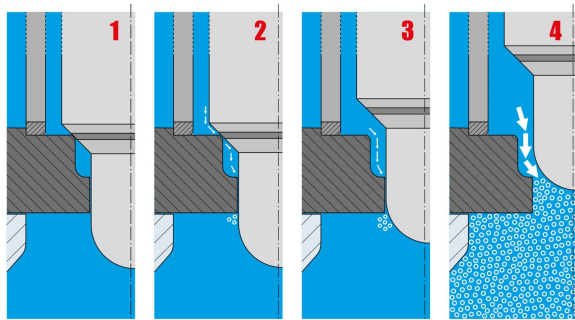

Design features

1. Angle type valve body
2. Separate sealing and control seat
3. Fully stellite seat
4. Increased outlet diameter
5. Available in F12, F22 and P91 material

We strongly advise to have a minimum amount of elbows in the valve outlet piping

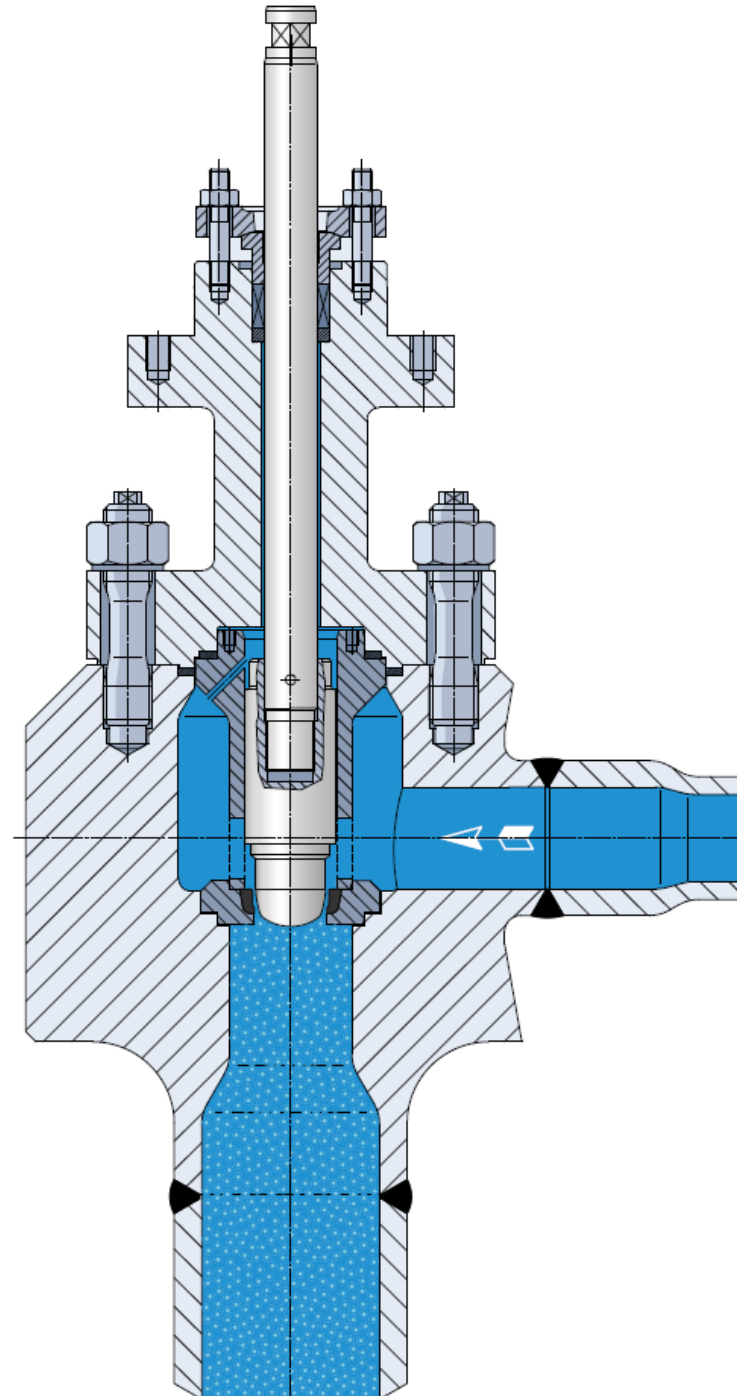

Typical drain valve, separated seat and control, clamped trim
Forged body, increased diameter outlet

Advanced Valve Solutions USA Inc.

7 Wells Street, Saratoga Springs NY 12866 - USA - Tel: 518 260 2574
E-mail: info@advancedvalvesolutions.com - web: www.advancedvalvesolutions.com